

| REV. E.C.D. | DESCRIPTION | DATE | BY | APP'D. |
|-------------|---------------------|----------|----|--------|
| Y 2633 | ADD LEVEL INDICATOR | 09/20/06 | GL | JK |

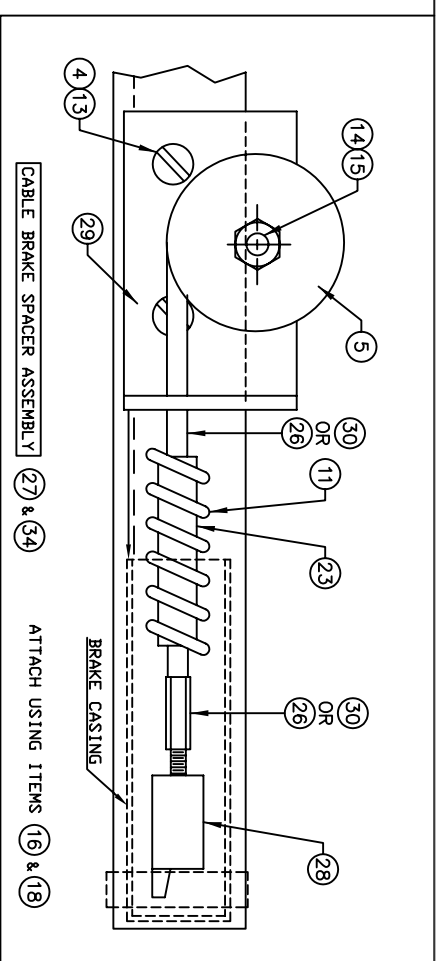

ALL DIMENSIONS IN [] ARE IN MILLIMETERS
 NOTE: REF. DWG. B0090147 AND B0090148
 FOR DETAIL OF ATTACHING OUTRIGGER PINS
 AND CHAINS.

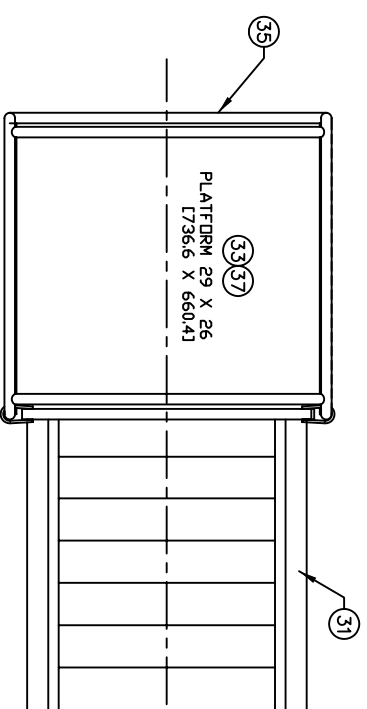
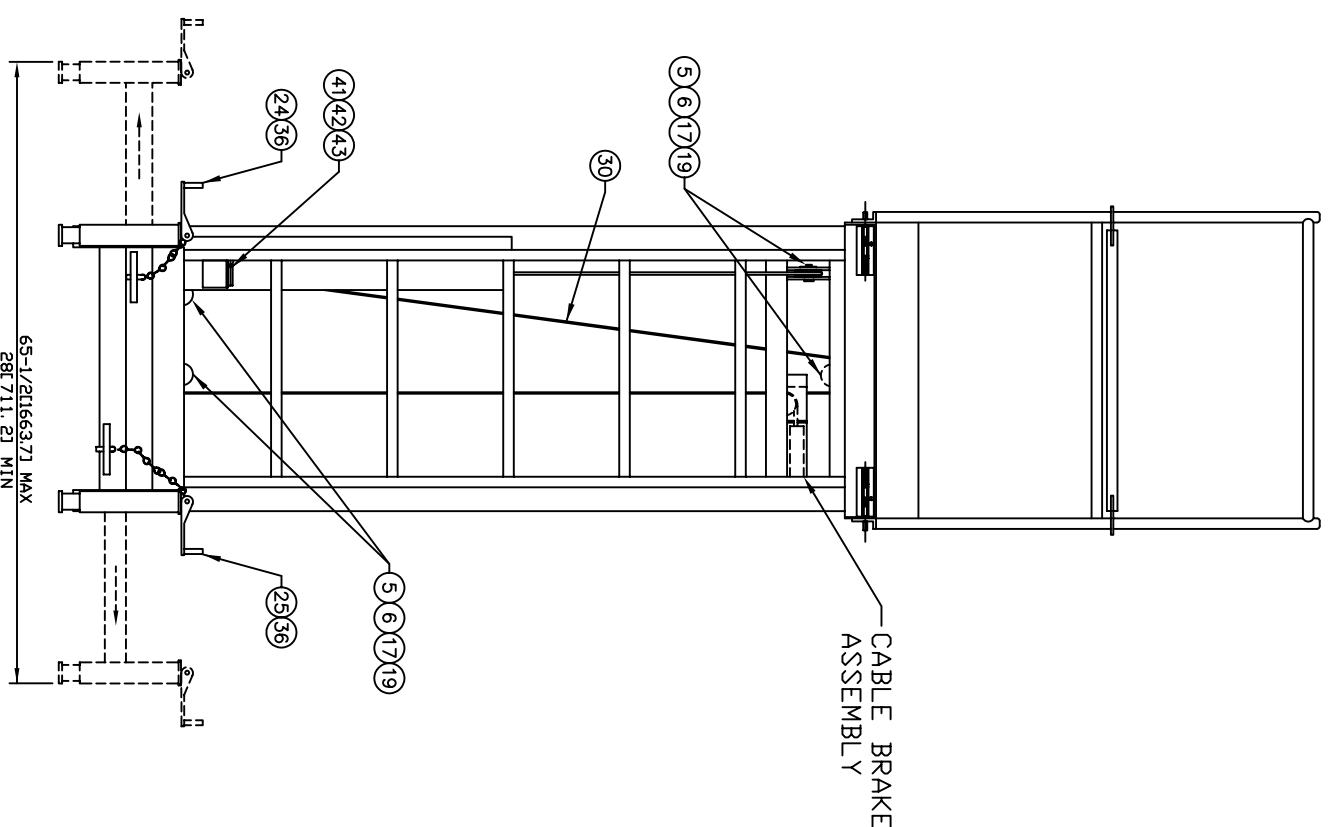
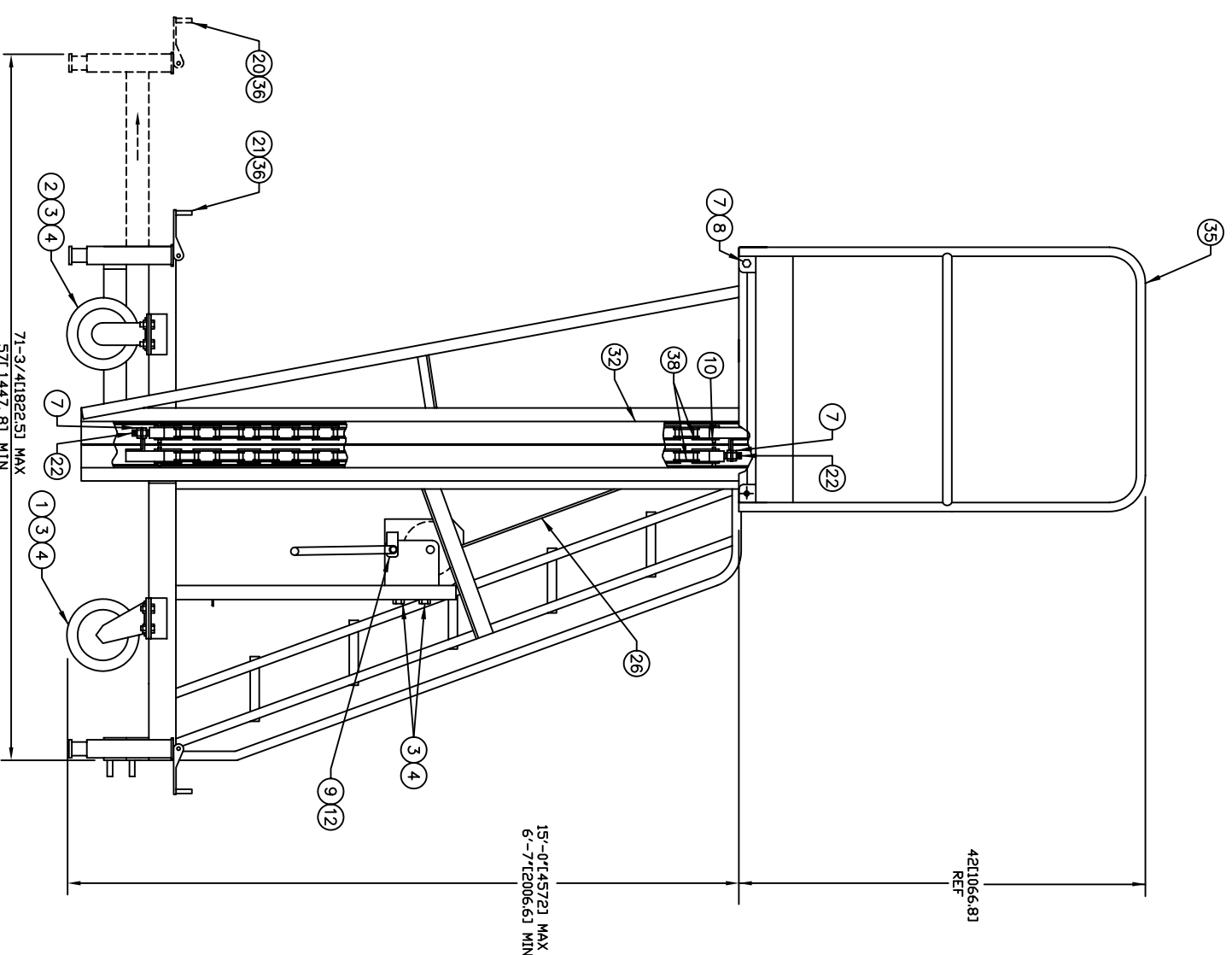

| * NOT SHOWN | QTY | | |
|---------------|----------|-------------|-----|
| 43 A-301-0620 | 2 | | |
| 42 A-301-0619 | 1 | | |
| 41 A-301-0101 | 1 | | |
| *40 A0091000 | 1 | | |
| 39 C0080015 | 1 | | |
| 38 A-009-0288 | 2 | | |
| 37 A-302-0001 | 2.333 FT | | |
| 36 A-009-0386 | 4 | | |
| 35 C-9-6 | 1 | | |
| 34 C-9-43 | 1 | | |
| 33 C-9-44 | 1 | | |
| 32 C-009-0079 | 1 | | |
| 31 D-009-0015 | 1 | | |
| 30 B-009-0063 | 1 | | |
| 29 B-9-60 | 2 | | |
| 28 B-9-58 | 2 | | |
| 27 B-009-0102 | 1 | | |
| 26 B-009-0093 | 1 | | |
| 25 A-9-4 | 1 | | |
| 24 A-9-3 | 1 | | |
| 23 A-9-216 | 2 | | |
| 22 A-9-185 | 2 | | |
| 21 A-9-2 | 1 | | |
| 20 A-9-1 | 1 | | |
| 19 A-301-0535 | 4 | | |
| 18 A-301-4404 | 4 | | |
| 17 A-301-3106 | 7 | | |
| 16 A-301-1301 | 4 | | |
| 15 A-301-1151 | 2 | | |
| 14 A-301-1150 | 2 | | |
| 13 A-301-1149 | 2 | | |
| 12 C-009-0094 | 1 | | |
| 11 A-301-1146 | 2 | | |
| 10 A-301-1143 | 4 | | |
| 9 A-301-1116 | 1 | | |
| 8 A-301-1114 | 2 | | |
| 7 A-301-1104 | 6 | | |
| 6 A-301-1057 | 4 | | |
| 5 A-301-1018 | 6 | | |
| 4 A-301-0988 | 26 | | |
| 3 A-301-0452 | 27 | | |
| 2 A-301-0302 | 2 | | |
| 1 A-301-0203 | 2 | | |
| DET MATL/PART | DWG | DESCRIPTION | QTY |



THIS DRAWING IS COMPUTER GENERATED.

| DWN | DATE | DATE | DATE |
|-----|---------|------|------|
| DWN | 5-4-82 | | |
| CKD | | | |
| APD | 5-18-82 | | |

THIS PRINT IS THE PROPERTY OF COTTERMAN COMPANY AND MUST NOT BE USED IN WHOLE OR PART WITHOUT WRITTEN PERMISSION.
 PLEASE RETURN ON DEMAND.

COTTERMAN COMPANY
 130 SELTZER RD, CRUSWELL, MI 48422

ML-15W MAXI-LIFT WITH BRAKE
 PART NO. D-009-0014 DWG. NO. D0090014
 SCALE 1/8"=1" SHT. 1-1